

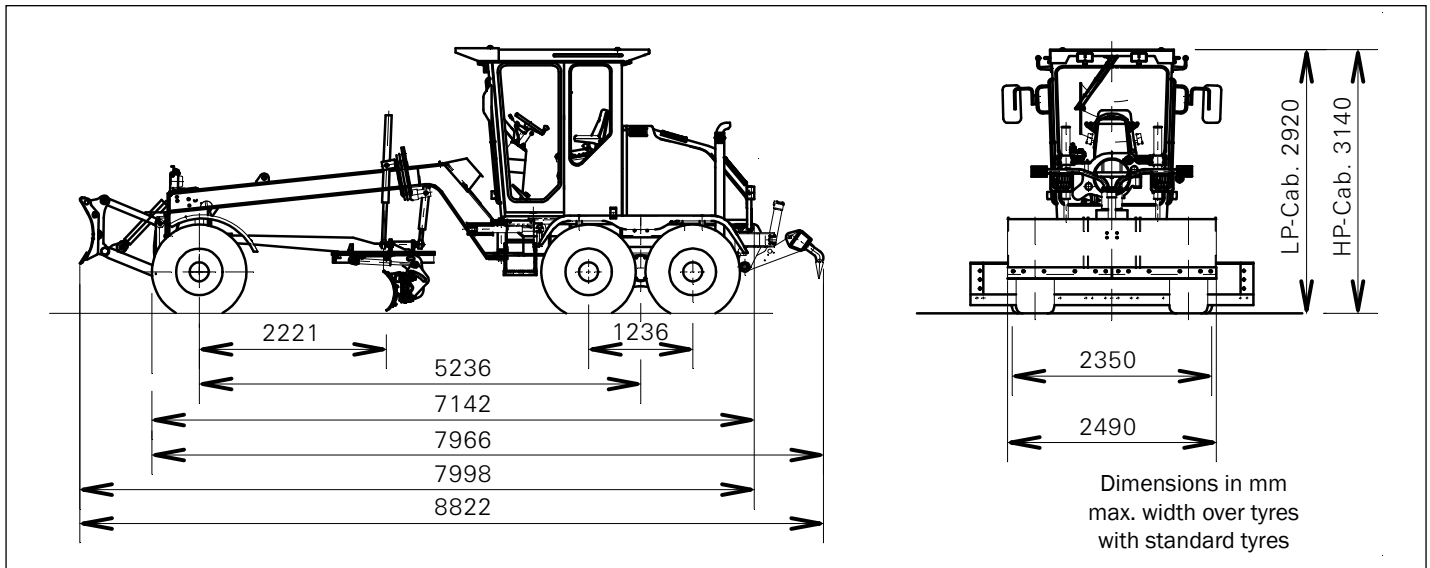

Motor Grader

BG 110 T-4 (6x4) / BG 110 TA-4 (6x6)



Engine Data

Make/Model	PERKINS/diesel engine
Type	4 cycle, direct injection, turbo-charged, water-cooled intercooled
Rated net horsepower (ISO/TR 14396) at 2200 rpm	97 kW/132 HP
No. of cylinders	in line 4
Bore & stroke	105 x 127 mm
Displacement	4.4 litres

Engine equipped with dual element, dry-type air cleaner with dust ejector. 24 volt starting and electrical system. 80 amp alternator and 24 volt starter with 4.5 kW (6.1 HP). 2 batteries 74 Ah each.



Speeds

(all wheel drive and rear axle drive systems)

	km/h
Forward	
1.	4.0
2.	7.0
3.	12.0
4.	18.0
5.	25.0
6.	40.0
Reverse	
1.	4.0
2.	12.0
3.	25.0

Acoustic back-up alarm in reverse driving



Operating Weight

Total weight	approx. 10900 kg
On rear wheels	approx. 7500 kg
On front wheels	approx. 3400 kg

Weights shown include cab, all operating fluids, rear ripper (width 1920 mm), front dozer blade.



Rear Axle

Oscillating tandem axle with axle insert.
No-Spin differential
Multi-disc brakes in all four wheel hubs.
Parking brake at powershift transmission.



All Wheel Drive System

Hydrodynamic rear axle drive with 6-speed Ergopower transmission and torque converter (make ZF 6 WG) with freely selectable micro-processor controlled hydrostatic front axle drive. Power train is controlled appropriate to tyre traction.



Tandems

Drive via roller chains.
Torsion-proof box sections.

Height	450 mm
Width	171 mm
Thickness of walls	15/18 mm
Wheel base	1236 mm
Oscillation	±15°
Ground clearance	380 mm



Rear Axle Drive System

Hydrodynamic rear axle drive with 6-speed Ergopower transmission (make ZF 6 WG) and torque converter.



Wheels & Tyres

Tyre size	405/70 R20 radial
Rim size	13.00 x 20



Brakes

Service brake

Dual-circuit, power-assisted, multi-disc oil-bath type, effective on four wheels. Includes reserve power and operator warning system.

Parking brake

Independent electrically operated brake, acting on rear axle. Hydraulic spring accumulated single disc type.



Front Axle

2 types are available

Oscillation	15° up and down
Steering angle	45°
Wheel lean	±17°
Ground clearance	500 mm

Non driven with wheel lean (T version)

Stable welded steel beam with wheel lean.

Driven with wheel lean (TA version)

Stable welded steel beam with wheel lean.

Radial piston engines in wheel hubs.

Pulling power electronically adjustable (infinitely variable depending on surface conditions.).

Possibility to fit in the hydraulic differential lock.



Steering

Hydraulic power steering	
Minimum turning radius without dozer blade	6400 mm
Minimum turning radius with dozer blade	7050 mm
Steering angle	45°



Frame

Front and rear frame sections are connected with an adjustment free articulation pin.

Front: Fully welded rear box section.

Minimum dimensions of box section	240 x 240 mm
Plate thickness	20/12 mm

Rear: Fully welded rear frame

Dimensions (solid main bars)	210 x 70 mm
------------------------------	-------------

Hydraulic articulated frame steering (left & right)	30°
---	-----



Circle (closed version)

Hardened teeth, machine-cut on inside of circle for maximum strength and minimum wear. The circle is held positively in place by an adjustment free roller bearing.

Diameter	1348 mm
Tooth width	78 mm
Height	130 mm
Distance blade/front axle	2221 mm



Circle Drive

Hydraulically driven worm gear transmission. Circle drive system is fully protected against impact damage by an overload clutch.

Rotation	360°
----------	------



Drawbar

A-shaped fully welded construction.

Dimensions (solid sections)	30 x 170 mm
-----------------------------	-------------



Moldboard (standard)

Moldboard (10 ft)	3050 x 505 x 15 mm (10' x 19,9" x 0,6")
Blade material	High carbon steel
Blade pull (at a friction factor of 0.8)	BG 110 T-4 61 kN BG 110 TA-4 81 kN



Blade Range

Reach outside tyres without articulation (RH&LH), blade resting on levelled surface	2250 mm / 1690 mm
Reach outside tyres with articulation (RH&LH), blade resting on levelled surface	2820 mm / 2260 mm
Blade side shift	1000 mm
Blade tilt range	40° - 80°
Bank sloping angle (RH&LH)	90°
Lift above ground	455 mm
Cut below ground	430 mm
Distance blade/front axle	2221 mm

All blade movements and positions can be controlled from the operator's seat.



Operator's Platform

Dimensions	
Width	1150 mm
Depth	1400 mm

Available with various options as listed under "Optional equipment", moldboard control acc. to EURO standard.



Capacities

Fuel	195.0 litres
Hydraulic oil	140.0 litres
Engine oil	12.0 litres
Ergopower transmission	30.0 litres
Axle drive rear	11.0 litres
Planetary gears and brakes	8.0 litres
Tandem case (2 x 18 litres)	36.0 litres
Circle drive	6.0 litres
Coolant	25.0 litres



Light Equipment

2 head lights at the front, every 2 indicator lights (including hazard warning lights) at the front and rear, 2 rear lights, 2 brake lights, 1 backup light plus every 2 working lights at the top and bottom at the front of the cab, 2 working lights at the top at the rear of the cab, and 2 tail lights on the sides.



Load-Sensing Hydraulics

The control valves of the working hydraulics may be actuated at a time and independent of each other. The load-sensing pump (axial piston pump) discharges only the required quantity of oil if a control valve is actuated. When hydraulic power is not required system pressure is only 24 bar and ensures low oil temperature und fuel saving.

Lock valves and brake valves prevent a cylinder drift under load.

Operating pressure	184 bar
max oil flow	100 l/min



Optional Equipment

Cab, standard, tiltable

Integrated ROPS/FOPS cab mounted on isolators to limit vibration and noise entering the cab. Excellent all-round visibility. Roomy and comfortable. Adjustable steering pedestal with EURO control lever arrangement. Interior of cab fully lined, floor covering. Tinted safety glass windows, sliding doors left and right with lockable intermediate positions, fresh air heating with pre-filter, air circulation. Adjustable, mechanical spring mounted driver's seat with safety belt. One inside mirror and two folding outside mirrors.

Front window washer.

Wipers front and rear.

Blinds front and rear.

Hight / Width / Depth	1980 / 1470 / 1700 mm
-----------------------	-----------------------

Cab, low-profile, tiltable

Hight / Width / Depth	1760 / 1470 / 1700 mm
-----------------------	-----------------------

EP control panel (Joystick controls)

Air-condition for cab

Auxiliary heating

Heatable rear view mirrors

Beacon (orange)

Air cushioned drivers' seat

Recording speedometer

Cooling box

Stereo radio with CD-Player

Sliding side windows

Protective grids for cabin and lights

Moldboard (11 ft) 3355 x 505 x 15 mm (11' x 19,9" x 0,6")

Moldboard (12 ft) 3660 x 505 x 15 mm (12' x 19,9" x 0,6")

Cover plate for upper guide rail of moldboard

Moldboard extension, left or right (1 ft) 305 mm

Adjustable moldboard corner shoes, left or right

Float position for both moldboard lift cylinders

Wheels and tyres

Tyre size 16/70-20 diagonal

Rim size 13.00 x 20

Tyre size 405/70 R24 radial

Rim size 13.00 x 24

Other tyres on request.

Front dozer blade with position indicator, parallel guided

Width/Height 2490 x 765 mm

Cut below ground 130 mm

Lift above ground 585 mm

Weight 760 kg

Rear ripper with depth penetration indicator, 4 teeth (max. 7)

Width 1920 mm

Ripping depth 260 mm

Lift above ground 450 mm

Weight 450 kg

Mudguards

on front wheels

Mudguards

on rear wheels

Protective covers for transmission in different versions

Articulation angle indicator

Biological Oil in hydraulic system

Special paint

Fuel tank pump with automatic switch-off

Tool kit, wheel chocks, warning triangle, fire extinguisher, first aid kit etc.

Automatic blade control

Various 2D / 3D / GPS systems

CE certificate

Speed limitation at 25 km/h possible

GP Papenburg International GmbH



GP Günter Papenburg AG

headquarter

Ruhlsdorfer Straße 100 · 14513 Teltow · Germany

Tel: ++49 (0) 3328 456-412 · Fax: ++49 (0) 3328 456-251

E-Mail: vertrieb-international@gp.ag · www.gp.ag



Rothenburgstraße 20 · 99734 Nordhausen · Germany

Tel: ++49 (0) 3631 695-125 · Fax: ++49 (0) 3631 695-121

E-Mail: vertrieb-international@gp.ag · www.gp-papenburg.de/hbm-nobas

